

JUMBO LONG HOLE "RAPTOR"

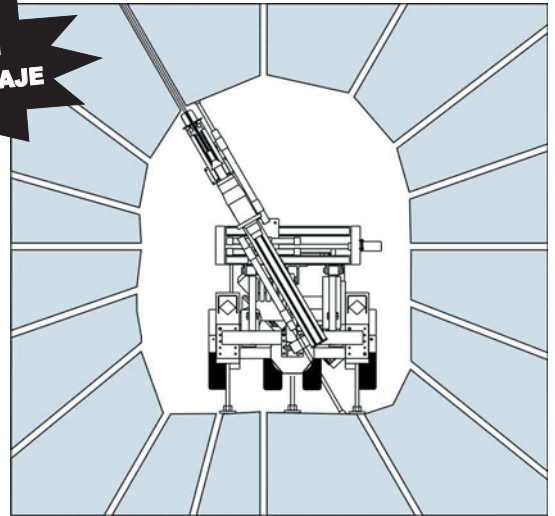

VIGA CON DOBLE ANCLAJE



PRINCIPALES COMPONENTES

- CARRIER** : RDC3, de 4 llantas, autopulsado
 Largo : 4.30 mts.
 Ancho : 1.90 mts.
 Altura : 2.15 mts.
 Peso : 3,850 Kgs.
- (*) PERFORADORA** : De 15 Kw de Potencia de Impacto
- VIGA LONG HOLE** : Modelo LH-1305 utiliza barras MF de 5 o 4 pies de longitud
 Incluye Mordaza Hidráulica
- PANEL DE MANDOS** : MR-12 Cable Eléctrico control remoto
- POWER PACK** : 55 Kw, con bomba Rexroth A10V071
- BRAZO** : Viga con corredera lateral
- TABLERO** : Estrella triángulo, 440 volts, 60 Hz
- BOMBA DE AGUA** : Grundfos CR4-60

(*) El modelo y marca que el cliente prefiera (El equipo se puede suministrar sin perforadora)

- APLICACION :**
- ✓ Sublevel Stopping
 - ✓ Sublevel Caving
 - ✓ Perforación de chimeneas

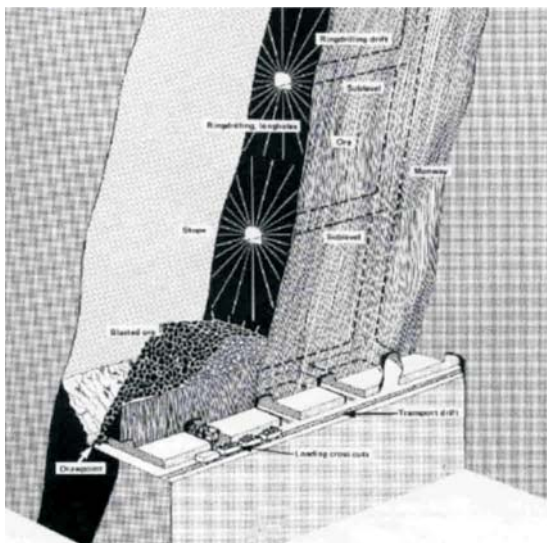

CAPACIDAD DE PERFORACION

- ✓ Full 360°
- ✓ Taladros paralelos, 1.70 mts de corredera
- ✓ Perforación : hasta 40 mts, de 2 a 3.5" Ø

VENTAJAS

- ✓ Optimo anclaje de la columna de perforación debido a 2 gatos hidráulicos, uno para el techo y otro para el piso
- ✓ Velocidad de perforación doble a triple del equivalente neumático
- ✓ Ahorro de 50% en el consumo de energía
- ✓ Ambiente de trabajo más limpio
- ✓ Excelente control de la perforación debido al panel de Cable Control Remoto

OPCIONAL: DTH

Con martillo Down The Hole hasta 5" Ø



RESEMIN



Galvani Mz I Lt.22 Urb.Ind. Santa Rosa, Ate, Lima-Perú resein@millicom.com.pe
 Telf.: 326 2617 326 1425 326 1976 326 5329 Fax:(51-1) 326 0442

RESEMIN

LONG HOLE RAPTOR

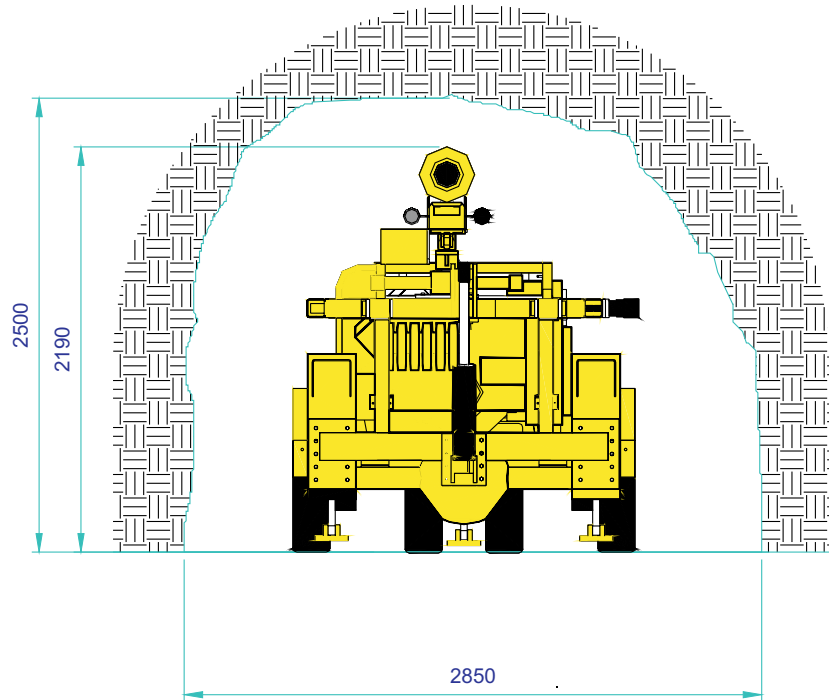
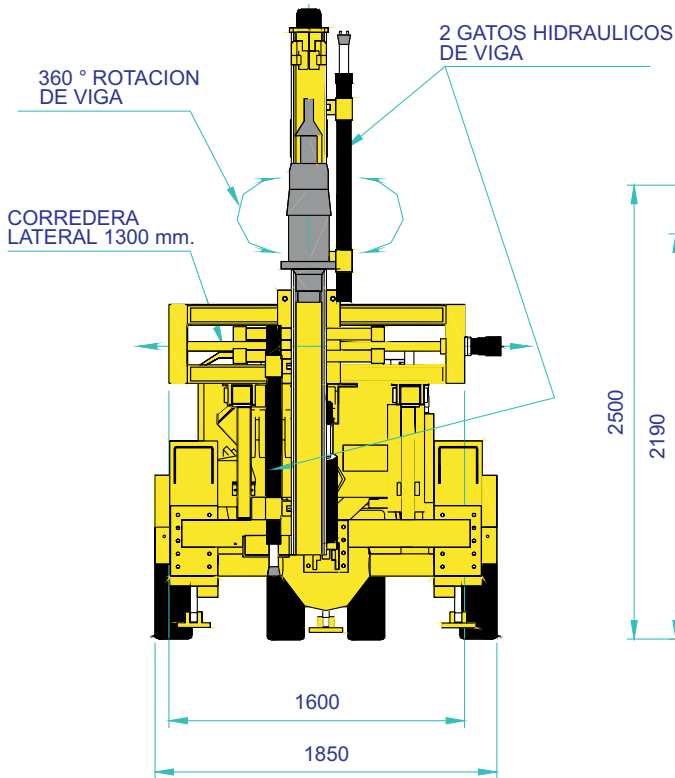
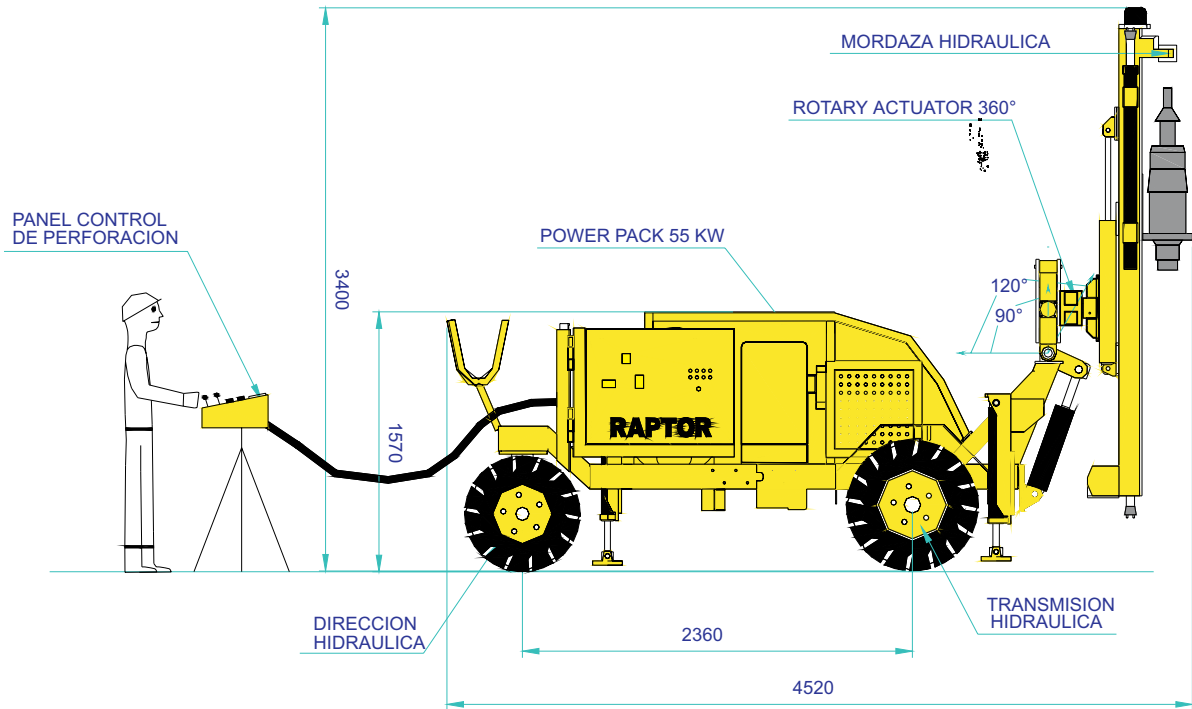

Distribuido por:

RAPTOR 33 - Long Hole and Front (Side) Face Jumbo

Specifications:

- Electro - Hydraulic Jumbo.
- Compact design, for sections of 2.4 x 2.4 mts.
- COP1238ME Atlas Copco powerful rock drill.
- Long Hole Feed model LH-1303, for rods MF 3'
- Superior drilling control by means of Panel Remote Control MR-12.
- Horizontal Sliding, displacement effective 1.02 mts. for parallel drills.
- Rotation of the Feed: 360°, by means of Rotary Actuator.
- Self propelled carrier by means of power electric.
- Designed for one only operator.

Drilling Capacity (Long Hole)

- Full 360°
- Length: up to 35mts, diameters 51 to 89 mm.
- Effective parallel drills: 1.02mts.
- Minimum height of the heading : 2.40mts.
- Minimum width of the heading : 2.40mts.

Drilling Capacity (Breasting)

- Drilling holes for "Breasting" up to 2.1 mts. from ground and 5.0 mts length, diameters 45 - 51 mm.

Applications:

- Sub Level Stopping.
- Sub Level Caving.
- Breasting (Special Applications).
- VCR Shaft.
- Cable Bolting.

Advantages:

- Specially designed to be introduced - complete or in parts - through shafts for access to "captive" headings.
- Can be easily assembled or disassembled.

"For Small Sections "

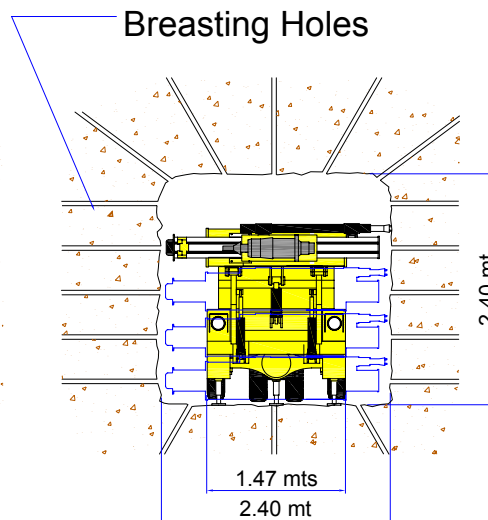
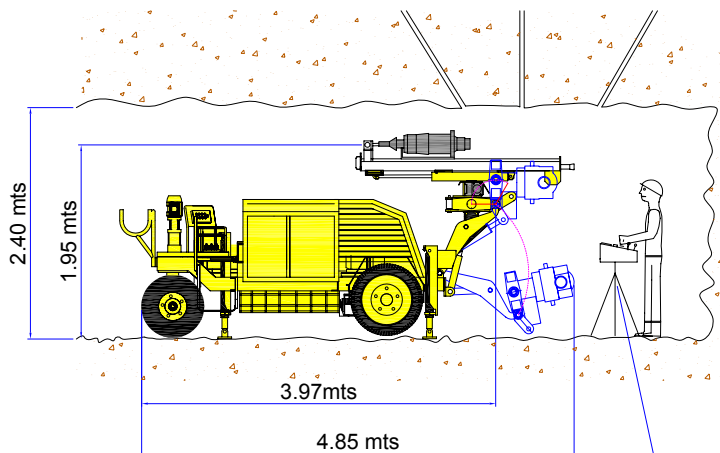

Panel Remote Control

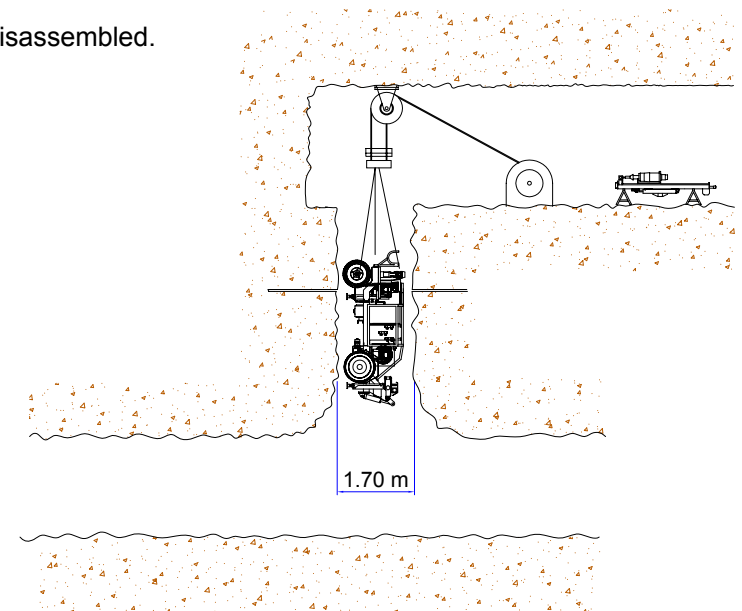

Dibujado C.C.G.L.	Revisado C.García	Aprobado Ing. James Valenzuela	Filename PLF	Date 20.10.03	Scal 1:10
Owner RESEMINA		Title/Name RAPTOR 33		Customer	
				Edition She	